

Series Active Filter For Self Excited Induction Generator Feeding Nonlinear Load

Abhishek Dubey¹, Suchi Mishra² and Sachin Tiwari³

¹Department of Electrical Engineering, Scope College of Engineering, Bhopal.

²Department of Electronics & Instrumentation, SATI, Vidisha.

³Department of Electrical and Electronics Engineering, Oriental Institute of Science and Technology, Bhopal.

Abstract— This article deal with series active filter (SAF) based controller to improves Power quality and voltage controlling a self-excited induction generator (SEIG) powered through a constant speed prime mover feeding a three phase nonlinear load. the continuously moving principal mover driven SEIG have problem of poor power quality and voltage regulation. The always-moving primary mover are a diesel motor, biomass, gas turbine etc. The voltage stabiliser is modelled utilising a voltage controlled voltage source converter (VCVSC) based on an IGBT (Insulated Gate Bipolar Junction Transistor) and a self-supporting DC bus. In series with the system voltage, the SAF is injecting a voltage. Utilising MATLAB, Simulink, also the with the help of the power system block set (PSB) toolbox, a 7.5Kw, 415V, 50Hz asynchronous generator-based generating system with SAF is developed and simulated. The reported simulation results show how an voltage controller-equipped asynchronous generating system can supply a changing consumer load.

KEY WORDS: DISTRIBUTED GENERATION, PERMANENT SPEED PRIME-MOVER, ASYNCHRONOUS GENERATOR, ACTIVE FILTER, SERIES, POWER QUALITY.

I. INTRODUCTION

Another significant challenge with distributed generation is concerns with power quality, like sag, aberrations to the sinusoidal waveform, such as swells and transients. UPQC, DSTATCOM, Series Dynamic Filter, Shunt DVR, UPQC, and Active Filter are utilised to enhance power efficiency. Improvements in source current power quality are made by the DSTATCOM and Active Shunt Filter. To be able to enhance the the strength of the load terminal voltage, The DVR and Series Active Filter are utilized. Additionally, UPQC has the ability to improve the standard of the provided power by the load voltage and source current.

The term "distributed generation" refers to the scattered power generating at the center of load where the electricity produced is sent immediately to the burden. Particularly in rural areas location of the utility system unable to deliver distributing the power generating is a useful possibility. The main topic of attention for the entire world now is global warming. The earth is getting hotter as petroleum and coal are examples of fossil

fuels. Products are used more frequently. The transfer of energy from renewable sources including wind, hydro, biomass, solar, etc. is what power generating is. For distributed generation, the SEIG, short for self-exciting induction generator is advised because to its affordability, low maintenance requirements, durability, and brushless design. The core issues through the SEIG are related to due to its incapacity regulate voltage at the terminals under various load situations. A restriction of an asynchronous generating using a capacitor personal elation is inadequate power control, This causes the device being underutilized. To maintain a balance between its maximum power and the weight of run at its rated capacity, the machine needs a source of reactive energy from outside current. [1,3]

This tiny hydro is a continuous primary mover of power that has a frequency stability issue when the load changes. For this application, there is adequate literature on a rectifier-based electronic load that is regulated or uncontrolled. Controllers (ELCs) for controlling the asynchronous generator's frequency. [4] Although the frequency of the gas turbine, diesel and biomass engines is constant, when the load changes, the voltage control issue arises. Reactive power compensators, Various devices, including the DVR, static compensator, and UPQC (STATCOM), are utilized in this application to regulate voltage. STATCOM has already received a lot of work. [5-7] Wind power is a prime mover with variable power and speed that has controllability issues with frequency as well as voltage. With power sources or loads that are both reactive and active, this application employs a voltage and frequency controller. [8-9] Try to focus on this here. prime mover-based power generation using diesel, gas and biomass at constant speed.

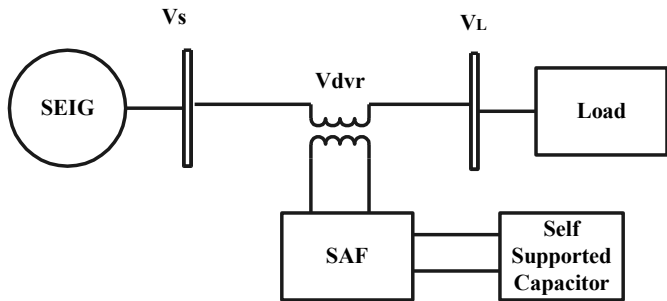

Figure 1. Schematic Illustration of SAF Connected SEIG

The SAF is power electronics device that uses voltage source converters (VSCs), transformers, and capacitors coupled at the load, the source, or a location in between the two that is in series. Figure 1 shows a schematic for a capacitor-supported SAF. Although the supply power is off balance or deformed, SAF may return when the weight side power is a balanced sine wave voltage through the proper intensity. Consequently, enhancing the power quality of the voltage at the load terminal. As a result, it can shield crucial customer loads from supply disruptions. In a fault condition, SAF also enhances steady state stability and transient stability roughly equally. The rating of the capacitor in this instance also lessens shunt compensation. Additionally, by lowering the Short circuit current is reduced, the capacitor's protection is made easier, and the voltage profile over the entire line is also enhanced. A system with three phases and four wires that a dynamic force filter to provide non-linear loads with harmonic and reactive power adjustment is described in [2]. The performance of self-exciting induction generators can be improved by series compensation, according to [10]. [11] provides a description of a set of active power filters that uses using a hybrid strategy to control. Presentation of PSCAD/EMTDC's modelling and analysis of unique power systems in [12]. [13] discusses the construction

using a DVR for distorted and unbalanced loads that is supported by capacitors. It is described in [14] in what way to control a DVR that is supported by capacitors using adaline. Researchers looked on a potential method for regulating the voltage of a self-excited induction generator industrial applications in [15]. The transient behaviour of a Induction generator with three phases that self-exits when feeding dynamic loads is discussed in [16]. The performance of shunt and series compensators based on VSC that are used for the purpose of controlling load voltage in distribution systems is investigated in [17]. Wind farms may be more stable if they make use of a squirrel-cage induction generator, which is used as part of the control system for a digital video recorder [18].

Voltage sags and swells happen more frequently and result in serious issues and financial losses. Harmonics in voltage and current lead to a variety of problems, including increased power losses, uneven heating, and torque pulsation on the generator shaft. Other issues include flickering, unbalanced voltages, and unbalanced voltages and currents. As a result, the investigation here examines an adequate voltage controller, a three-phase load, and the definite and effectual functioning of a generator of induction that self-exits. It controls voltage. when used Using a voltage source with three legs for voltage adjustment. Converter, regulates the system's voltage while delivering the required reactive power. In DVR, a Hysteresis controller technique is introduced to manage the system's voltage. Simulink, PSB toolkit for power system blocks, and MATLAB are used to represent the entire system. The simulation results demonstrate the ability a power controller pertaining to an asynchronous generator to provide the three-phase load.

CONFIGURATION AND CONTROL OF THE SYSTEM SCHEME

The setup of the system depicted in Fig. 2 includes a biogas or diesel constant speed prime mover, SEIG, excitation capacitor, series active filter, and consumer loads. a capacitor on the DC bus an IGBT-based VSC make up the SAF. through an isolation transformer, an interface inductor, and a capacitor filter. The three-phase capacitor bank with a star connection is used to supply the generator with the necessary reactive power so that it can output its rated voltage when there is no load. Under a variety of load conditions, SAF satisfies the additional need for reactive energy. Between the source and the loads, the terminal voltage must remain constant. This SAF functions as per reactive power basis and sink. A power electronic device known as the VSC is capable of creating an ac voltage of any size, frequency, and phase angle, and it is conceivable to do so in any combination. In order to get the required level of output voltage, the VSC must be turned. Voltage regulation is one of the many aspects of power quality that are measured by the VSC. Other aspects measured include flicker and harmonics.

Critical loads are protected from any supply side disturbances aside from outages by the VSC-based series compensator. For the purpose of regulating active power flow, With the line voltages, it injects voltage in quadrature. Because it doesn't require reactive power from SEIG, it is a flexible controller. Through the use of VSC and a DC capacitor, it has its own reactive power supply. Series active filters are able to control Because of this quality, both reactive and active power are present inside the constraints imposed by their ratings.

In Fig. 3, the SAF control formula is displayed. The basic power that was injected's in-phase component is estimated using the PI (Proportional-Integral) controller. supply currents that are in phase (isa, isb, and isc) are used to create the unit voltage templates for three phases (usad, usbd, and uscd). The SAF's voltage on a DC bus is controlled by a PI controller over the reference value (V_{dc}^*) and detected (V_{dc}) values.

The injection voltages' in-phase component (v_{sa}^* , v_{sb}^* , and v_{sc}^*) is produced by multiplying this PI controller output's amplitude (V_{smd}^*) by templates for unit voltage (u_{sad} , u_{sbd} , and u_{scd}). Regarding the Bipolar Transistors with an Insulated Gate, gating signals are produced by the hysteresis controller using a component that is in-phase with both the recognized supply injection voltages (v_{sa} , v_{sb} , and v_{sc}^*) as well as the three reference voltages. The VSC's IGBTs are switched by gating pulses in order to provide V_{ca} , V_{cb} , and V_{cc} , which are used as compensation voltages.

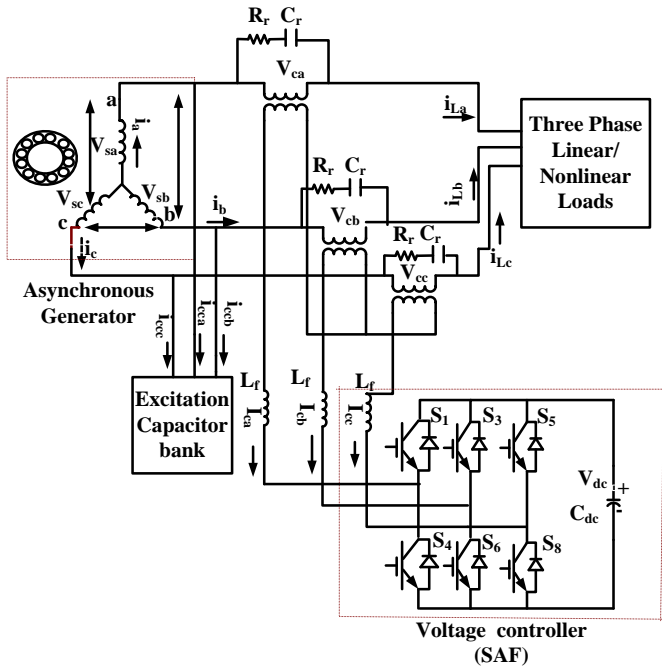

Fig. 2 Schematic diagram of proposed system configuration

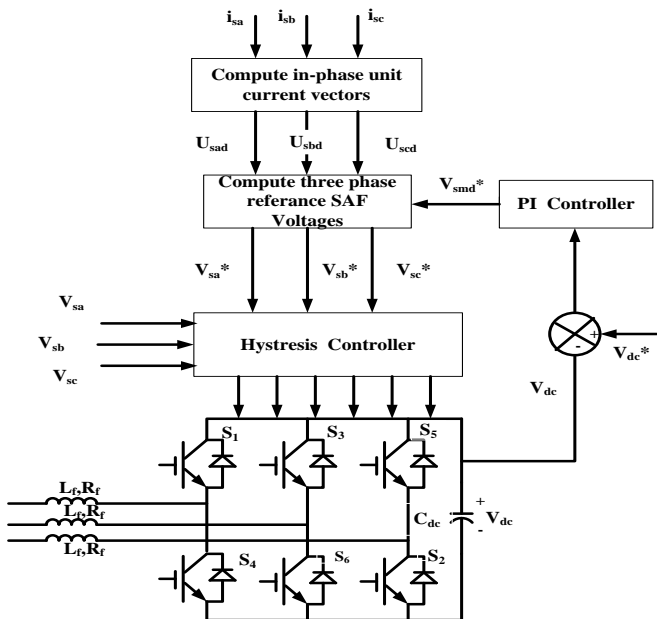

Fig. 3 Control algorithm of the SAF

II. MODELING OF IAG-SAF SYSTEM

The modelling of the asynchronous generator, the SAF, the interface transformer, the SAF control scheme, and the loads make up the mathematical model of the SEIG-SAF system.

A. Asynchronous Modelling Generator

By producing torque, the self-excited asynchronous machine acts as an SEIG. via a primary mover with a constant speed. The Simulink library contains the stationary reference Asynchronous machine model with d-q axes. The gadget is put through a synchronous speed test. Used to identify the saturation feature. The Equations for d-q axis flow in state space for asynchronous machines are as follows: [5]

$$p\phi_{ds} = v_{ds} - R_s i_{ds} \quad (1)$$

$$p\phi_{qs} = v_{qs} - R_s i_{qs} \quad (2)$$

$$p\phi_{dr} = v_{dr} - R_r i_{dr} - \omega_r \phi_{qr} \quad (3)$$

$$p\phi_{qr} = v_{qr} - R_r i_{qr} + \omega_r \phi_{dr} \quad (4)$$

The SEIG's produced torque is provided via

$$T_e = (3/4) p (\phi_{ds} i_{qs} - \phi_{qs} i_{ds}) \quad (5)$$

The rotor of the squirrel-cage voltages are

$$v_{dr} = v_{qr} = 0 \quad (6)$$

The following currents can be used to express the links between the d-q axis:

$$\phi_{ds} = R_s i_{ds} + L_m i_{dr}, \quad \phi_{qs} = L_s i_{qs} + L_m i_{qr} \quad (7)$$

$$\phi_{dr} = L_s i_{dr} + L_m i_{ds}, \quad \phi_{qr} = L_s i_{qr} + L_m i_{qs} \quad (8)$$

$$L_s = L_{ls} + L_m, \quad L_r = L_{lr} + L_m \quad (9)$$

The s, r, l , and m subscripts, respectively, the d and q axes represent the leakage, magnetizing, stator, and rotor amounts.

The magnetizing inductance L_m , which is expressed as the following polynomial, is the result of the asynchronous machine speed test using synchronous speed:

$$L_m = a + b I_m + c I_m^2 + d I_m^3 \quad (10)$$

The magnetizing potential of SEIG is calculated as: where are constants a, b, c , and d .

$$I_m = \{(i_{ds} + i_{dr})^2 + (i_{qs} + i_{qr})^2\}^{1/2}/\sqrt{2} \quad (11)$$

The major actuator torque speed feature is as follows:

$$T_{sh} = K_1 - K_2\omega_r \quad (12)$$

Where r is the rotor speed and Constants k_1 and k_2 are provided in the appendix. the current through (i_e) and the excitation capacitance (C_e). Following are the stator voltages for SEIG (v_s):

$$C_e p[v_s] = [i_e] \quad (13)$$

B. Simulation of SAF

The SAF is modelled as the following and is a current-controlled VSI. Its dc voltage's derivative is represented by:

$$pv_{dc} = (i_{ca}SA + i_{cb}SB + i_{cc}SC)/C_{dc} \quad (14)$$

The switch operations for the VSI Bridge switches' on/off locations $S_1 - S_6$ are $S_a, S_b,$ and S_c , respectively, where $p = d/dt$. At the inverter's output, the voltage on the dc bus reflected as the following is a textual representation ac line voltages that are three-phase PWM:

$$e_a = v_{dc}(S_A - S_B), e_b = v_{dc}(S_B - S_C), e_c = v_{dc}(S_C - S_A) \quad (15)$$

For the VSI of the SAF's output, the following volt-current equations apply:

$$v_a = Rfi_{ca} + Lfpi_{ca} + e_a - Rfi_{cb} - Lfpi_{cb} \quad (16)$$

$$v_b = Rfi_{cb} + Lfpi_{cb} + e_a - Rfi_{cc} - Lfpi_{cc} \quad (17)$$

$$i_{ca} + i_{cb} + i_{cc} = 0 \quad (18)$$

The following happens when the i_{cc} value switching from (18) to (17):

$$v_b = Rfi_{cb} + Lfpi_{cb} + e_a + rfi_{ca} + Lfpi_{ca} + Rfi_{cb} + Lfpi_{cb} \quad (19)$$

By reordering (16) and (19), they are modified:

$$Lfpi_{ca} - Lfpi_{cb} = v_a - e_a - Rfi_{ca} + Rfi_{cb} \quad (20)$$

$$Lfp i_{ca} + 2Lfp i_{cb} = v_b - e_b - Rfi_{ca} - 2Rfi_{cb} \quad (21)$$

In order to derive the SAF current derivatives, (20) and (21) are solved as per follows:

$$p i_{ca} = \{ (v_b - e_b) + 2(v_a - e_a) - 3Rfi_{ca} \} / (3Lf) \quad (22)$$

$$p i_{cb} = \{ (v_b - e_b) + (v_a - e_a) - 3Rfi_{ca} \} / (3Lf) \quad (23)$$

C. Transformer modelling

The magnetic flux created by the SAF currents in the transformer caused voltages V_{ca1} , V_{cb1} , and V_{cc1} to be induced across the SAF side.

$$V_{ca1} = 1.414 f \phi_{ca} N_1 \quad (24)$$

N is the quantity of turns across the transformer's SAF side, the frequency of, and f SAF currents and voltages. V_{ca} , V_{cb} , and V_{cc} are the voltages that the transformer pumped into the system.

$$(V_{ca}/V_{ca1}) = (V_{cb}/V_{cb1}) = (V_{cc}/V_{cc1}) = (N_2 / N_1) \quad (25)$$

N_2 is the amount of transformer turns on the system side.

D. Control system modelling of SAF

The following is a description about the SEIG-SAF system's control algorithm in three phases for feeding loads. Since SEIG's three-phase load currents are thought to be sinusoidal, these waves' amplitudes are calculated as follows:

$$I_{Lmag} = [2/3(i_{La}^2 + i_{Lb}^2 + i_{Lc}^2)]^{1/2} \quad (26)$$

Individual load currents are divided by their amplitude to calculate the unit voltage vectors that are in phase with,

$$u_{sad} = \frac{i_{La}}{I_{Lmag}}; u_{sbd} = \frac{i_{Lb}}{I_{Lmag}}; u_{scd} = \frac{i_{Lc}}{I_{Lmag}}; \quad (27)$$

1) The Voltage Vectors' Concurrent Component

The SAF, $V_{dcer}(n)$ mistake in DC bus Here is the voltage at the n^{th} sample point:

$$V_{dcer}(n) = V_{dc}(n)^* - V_{dc}(n) \quad (28)$$

Where $V_{dc}(n)$ is the detected DC link power of the SAF and $V_{dc}(n)^*$ is the standard DC voltage. To keep the SAF's DC bus voltage constant at the n^{th} sampling moment, the PI controller's output is denoted as.

$$V_{smd}(n)^* = V_{smd}(n-1)^* + K_{pd}\{V_{dcer}(n) - V_{dcer}(n-1)\} + K_{id}V_{dcer}(n) \quad (29)$$

Where $V_{smd}(n-1)^*$ is the magnitude of the voltage at the reference load's in-phase component is $(n-1)^{th}$ Immediate, K_{pd} , and K_{id} are the components of the PI controller's proportionate and integrated gain variables, respectively. Following are the calculations for the in-phase components of the reference load voltage:

$$V_{sa}^* = V_{smd}^* U_{sad}, \quad V_{sb}^* = V_{smd}^* U_{sbd}, \quad V_{sc}^* = V_{smd}^* U_{scd} \quad (30)$$

In order to create the pulses gating to reversing the IGBTs of the VSC, these reference load powers are compared to sensing voltages (V_{sa} , V_{sb} and V_{sc}).

E. Consumer loads simulation

Utilizing a a resistive element and The nonlinear demand is approximated using a three-phase diode rectifier. This three-phase load voltages V_{La} , V_{Lb} , and V_{Lc} in a nonlinear load are used to form the dc load voltage known as v_d . Id stands for direct current RL and load current for a an enduring burden.

$$I_d = \frac{v_d}{R_L} \quad (31)$$

III. DESIGN OF A SERIES OF ACTIVE FILTER

A. The design of the SAF takes into account both linear and nonlinear loads can be handled by the ripple filter, however dc bus power, the dc bus capacitance, the ac interfacing inductance, the voltage rating of the SAF's VSC, the SAF's VSC's current rating, expressed as a KVA rating, and the rating of the interfacing transformer..

B. VSC Design Voltage Rating SAF

SAF power strategy for nonlinear loads is dependent on the three phase rectifier load's dc bus voltage. The SAF removes harmonics from the load is just injected, not the source current power's harmonic component. Consequently, the essential element is as follows:

$$V_{LL} = (\sqrt{6}/\pi) V_d = 0.779 * V_d \quad (32)$$

V_d is 532.7 V where V_{LL} is the 415 V line power. The transformation between source terminal and power at the load is used to determine the SAF's voltage rating. Thus, the SAF voltage is determined as follows:

$$V_{C(rms)}^2 = \frac{1}{\pi} \left[\int_0^{\pi/3} (415\sqrt{2} \sin \theta - 0) d\theta + \int_0^{2\pi/3} (415\sqrt{2} \sin \theta - 532.7) d\theta \right] \quad (33)$$

C. VSC's voltage rating under a nonlinear load is $V_{c(rms)} = 145.56$ V. If linear and nonlinear loads are combined, the best voltage rating for VSC is $V_c = 150$ V.

D. VSC Current Rating Design

The basic a load current component determines the current rating of VSC in non-linear load scenarios. When a source current of one pf, a resistive load of 7.5 kW, and a load voltage are used, the current rating of VSC is calculated as follows $V_L = 415$ V:

$$I_s = P/(\sqrt{3}V_L) = 13.043A \quad (34)$$

The R_L is determined as the equivalence between the dc load's resistance and

$$P_{dc} = (V_d^2/R_L) \quad (35)$$

For $P_{dc} = 7.5$ kW and $V_d^2 = 532.7$ V, the $R_L = 37.84 \Omega$

E. KVA Rating of VSC of SAF

The VSC of the SAF's KVA rating is computed as

$$kVA = 3 V_c I_s/1000 = (3 * 158.4 * 13.043)/1000 = 6.198 \text{ kVA} \quad (36)$$

F. Injection Transformer Rating SAF

The injection transformer's and VSC's kVA ratings are same.

$$kVA = 3 V_c I_s/1000 = (3*158.4*13.043)/1000 = 6.198 \text{ kVA}$$

G. As a result, the injection transformer has a rating of 6.198 kVA, 158/158 V.

H. SAF's VSC's DC Capacitor Voltage

The dc capacitor voltage is dependent on the injection transformer voltage, which is 150 V on the VSC side.

$$V_{dc} > 2\sqrt{2} V_{C(s)} > 424.2 \text{ V} \quad (37)$$

Hence $V_{dc} = 450$ V is selected for SAF.

I. DC a capacitor for the VSC of SAF

Depending on the transient energy needed during a change in load situation, the capacitance of the dc bus chosen. Consider For a part of the power cycle, the energy reserve in the capacitor is assumed to be equal to the energy required by the load.

$$(1/2) C_{dc} (V_{dc}^2 - V_{dc1}^2) = 3 V_{ph} * I_{ph} * t \quad (38)$$

The required dc bus voltage is V_{dc} , and the voltage drop that permits transients is V_{dc1} , and t is the duration for which assistance is needed. Taking into account the following values: $t = 400$ s, $V_{dc} = 450$ V, $V_{dc1} = 450 - 2\%$ of $450 = 441$ V, and C_{dc} is the bus capacitance in dc.

$$1/2 * C_{dc} (450^2 - 441^2) = 3 * 239.6 * 13.043 * 0.40 \text{ ms}$$

$C_{dc} = 0.935$ mF, hence a dc bus of $1000 \mu\text{F}$, 450V is selected.

J. VSC of the Interfacing Inductor SAF

The ripple in the SAF current determines the value of the interface inductance (L_r). Consider a 5% ripple in the current; the charge of the inductance is then determined as per:

$$L_r = 0.866mV_{dc} / (6af_s\Delta I) \quad (39)$$

For a transformer rated at $158.4/158.4$ V, which has a primary side current of 13.043A , the secondary side current is also 13.043A . The f_s is set to 10 kHz, the loading factor is 1.2 , the modulation index is 1 , and I is considered to be on the safe side at 30A .

$$L_r = 0.866 * 1 * 450 / \{6 * 1.2 * 10k * (0.05 * 25)\} = 3.6 \text{ mH}$$

K. As a result, an interface inductor (L_r) with a current carrying capability of 30A and 3.6mH is chosen for the SAF.

L. Ripple Filter Design

That of the ripple filter design is influenced by the frequency of switching. The series inductor gives a high impedance channel for switching ripples, the capacitor provides a low impedance channel in contrast. with a switching frequency of half ($f_r = 5\text{kHz}$), the reactance given by the capacitor and inductor is computed as

$$X_{C_r} = 1 / (2 * \pi * f_r * C_r) = 1 / (2 * 3.14 * 5000 * C_r) \quad (40)$$

$$X_{L_r} = 2 * \pi * f_r * L_r = 2 * 3.14 * 5000 * L_r \quad (41)$$

For $X_{C_r} = 3\Omega$, $C_r = 10.61\mu\text{F}$ and for $X_{L_r} = 100\Omega$, $L_r = 3.18 \text{ mH}$

Design values of SEIG-SAF as seen in TABLE-I

TABLE-I SEIG-SAF system design parameters

	SEIG-SAF
Score the SEIG	7.5kW
Supplying power	415V
VSC KVA Score	6.198KVA
Current rating for VSC	13.043A

Bus Voltage DC	450V
Capacitance on a DC bus	1000 μ F
Filters	3.18mH,10.6 μ F
IGBT's current rating	24.2A
IGBT Voltage Rating	562.5V
Transformer score	6.198KVA, 158V/158V

III.RESULTS AND DISCUSSION

The generator is an asynchronous unit with 50 Hz, 415 V, and 7.5 kW. An excitation capacitor with a 5 kVAR delta connection generates the rated voltage. while there is no load, and the suggested controller also supplies reactive power when the weight varies. The capability it is the voltage controller thought to be demonstrated by the nonlinear loads. MATLAB simulates the operation of the SAF-based SEIG voltage regulation system feeding nonlinear loads for applications requiring consistent speed voltage waveforms from the generator (v_s), current source (i_s), excited state current, capacitance (i_{cc}), voltage at load (v_L), volts with SAF compensation (v_c), a current load (i_L), voltage on a DC connection (v_{dc}) and mechanical velocity (w_m) are shown in Fig. 4. Figure 5 displays the harmonic spectra for the three phase nonlinear load's sources of voltage, current, and loads of voltage and current. If the load is nonlinear, the voltage controller (SAF) may also keep THD The source voltage's (Total Harmonic Distortion) (V_s) and generator current (I_s) below IEEE-519 standards. A 7.5 kW, 415V, 4 pole SEIG with SAF was employed, and the Appendix has detailed specifications..

TABLE-II THDS OF VOLTAGES AND CURRENTS

THD of Source voltage	THD of SEIG Current	THD of Load voltage	THD of Load current
3.64	3.85	25.54	4.86

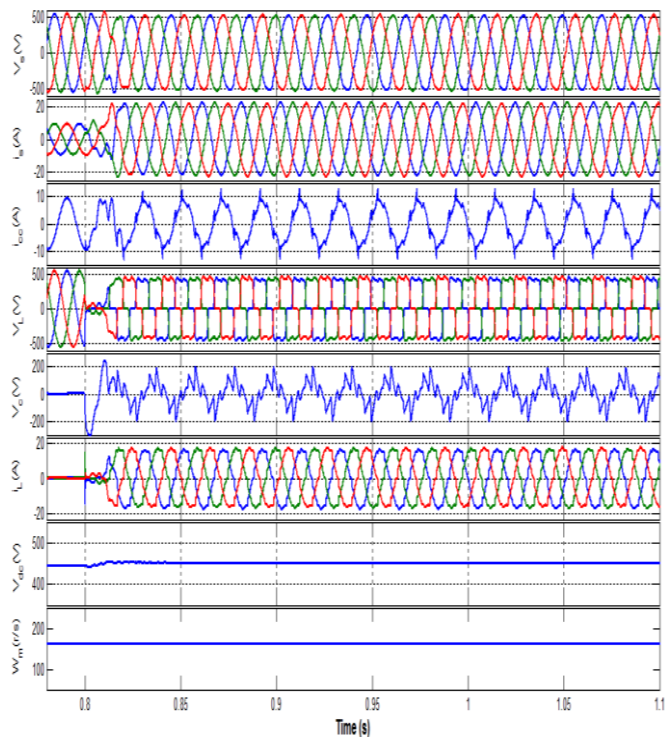

Fig.4 Compensation of voltage under 7.5 kW nonlinear loads

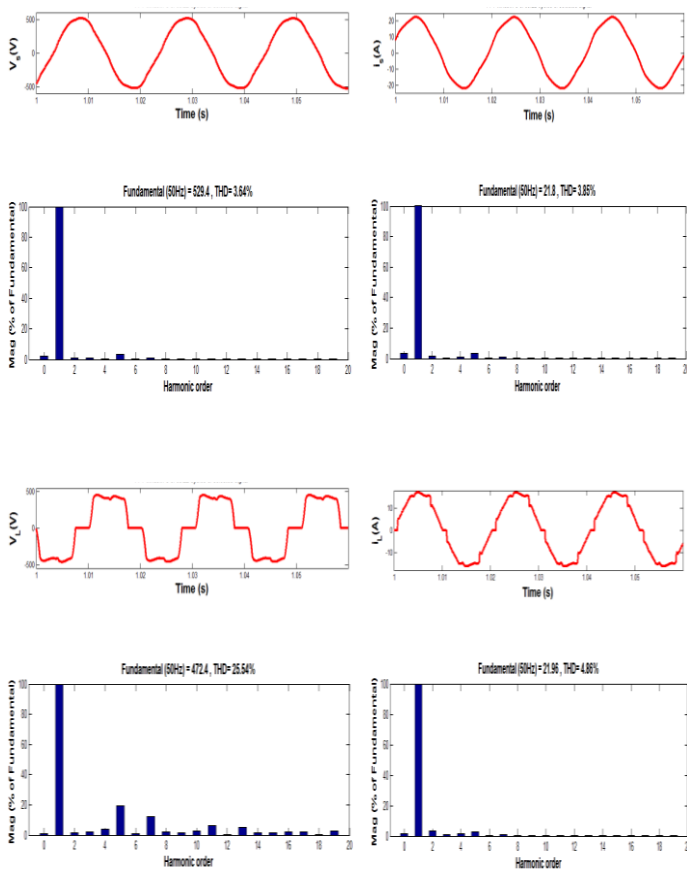

Figure 5 Harmonics spectrum of source voltage, source current, load voltage and load current of nonlinear load of 7.5kW resistive with rectifier

VI CONCLUSION

The ability inside the SEIG-SAF system to feed a phase three nonlinear weight in a continuous motion application has been established. A rectifier is used to power a 7.5kW resistive load that is fed by SEIG, 7.5kW, 415V, 50Hz. Simulated results using MATLAB have demonstrated very good performance. The proposed SAF controller is appropriate for improved power quality and effective voltage management even when the system is operating at full capacity. The scope of this work may also be expanded to include SEIG-DVR systems coupled to imbalanced objects.

VII. APPENDIX

A. The details for the 7.5kW, 415V, 50Hz, Y-Connected, 4-Pole asynchronous machine are listed below.

$$R_r = 0.77\Omega,$$

$$R_s = 1\Omega,$$

$$L_m = 0.134H \text{ (Im} < 3.16)$$

$$X_{lr} = X_{ls} = 1.5\Omega, J = 0.1384\text{kg-m}^2$$

$$L_m = 0.068H \text{ (Im} > 12.72)$$

$$L_m = 9e-5I_m^2 - 0.0087I_m + 0.1643 \text{ (3.16} < I_m < 12.72)$$

B. Controller parameters

$$L_f = 2\text{mH},$$

$$C_f = 10\mu\text{F and}$$

$$R_f = 4\Omega,$$

$$K_{pa} = 10, K_{ia} = 8.$$

$$C_{dc} = 1000\mu\text{F}.$$

$$K_{id} = 0.018.$$

$$K_{pd} = 0.0048,$$

For the DC link voltage, three single phase transformers with individual ratings of 3kVA, 400V/400V, and 450V are used.

C. Consumer Loads

Resistive three-phase power of 7.5 kw with a 0.8 pf load

D. Prime Movers Characteristics

$$E. K_1 = 16100,$$

$$F. K_2 = 100$$

$$T_{sh} = K_1 - K_2\omega_m$$

REFERENCES

- [1] S .P . Singh ,Bhim Singh and M. P . Jain, “Performance Characteristics And Optimum Utilization Of A Cage Machine As Capacitor Excited Induction Generator”, IEEE Transactions on Energy Conversion, vol. 5, No. 4. December 1990
- [2] B.Singh, K.Al-Haddad and A.Chandra, “Active Power Filter for Harmonic and Reactive Power Compensation in Three-Phase, Four-Wire Systems Supplying Non-Linear Loads”, ETEP vol.8 no.2.pp 139-145 March/April 1998
- [3] Bhim Singh, L.B. Shilpakar, “Analysis of a novel solid state voltage regulator for a self-excited induction generator”, IEE Proc.-Gener. Trans. Distrib., Vol. 145, No. 6, November 1998.
- [4] Singh, B.; Murthy, S.S. and Gupta, S.; , "An improved electronic load controller for self-excited induction generator in micro-Hydel applications," Industrial Electronics Society, 2003. IECON '03. The 29th Annual Conference of the IEEE , vol.3, no., pp. 2741- 2746 Vol.3, 2-6 Nov. 2003
- [5] Singh, B.; Murthy, S.S. and Gupta, S.; , "Analysis and design of STATCOM-based voltage regulator for self-excited induction generators,"IEEE Transactions on Energy Conversion, vol.19, no.4, pp. 783- 790, Dec. 2004.
- [6] Ahmed, T.; Noro, O.; Hiraki, E and Nakaoka, M.; , "Terminal voltage regulation characteristics by static var compensator for a three-phase self-excited induction generator,"IEEE Transactions on Industry Applications , vol.40, no.4, pp. 978- 988, July-Aug. 2004
- [7] Bhim Singh, and Gaurav Kumar Kasal,” Solid State Voltage Regulator for Isolated Asynchronous Generators Supplying 3-Phase 4-Wire Loads” , Proceedings of India International Conference on Power Electronics 2006..
- [8] Bhim Singh and Gaurav kumar kasal ,”Solid State Voltage and Frequency Controller for a Stand Alone Wind Power Generating system” IEEE Transactions on Power Electronics, Vol.23,no.3,May 2008.
- [9] D. K., Palwalia and S. P., Singh; , "Voltage and Frequency Regulation of Single Phase Self Excited Induction Generator," Electrical Engineering Conference, Dec-2008.
- [10] B Singh, L.Shridhar and C.S.jha “Improvement in the performance of self-excited induction generator through series compensation ”, IEE Proc. on Generation, Transmission and Distribution, vol. 146, no. 6, pp. 602 – 608,Nov. 1999.
- [11] Zhaoan Wang, Qun Wang, Weizheng Yao and Jinjun Liu, “A Series Active Power Filter Adopting Hybrid Control Approach”, IEEE Transaction on Power Electrinics, vol. 16 no. 3. May 2001
- [12] Olimpo Anaya-Lara and E.Acha, “Modeling and Analysis of Custom power systems by PSCAD/EMTDC”, IEEE Transaction on Power Delivery, vol. 17, no.1, January 2002.
- [13] A. Ghosh, A.K Jindal and A Joshi, “Design of a capacitor supported dynamic voltage restorer (DVR) for unbalanced and distorted loads”, IEEE Trans. on Power Delivery, vol. 19, no.1,pp. 405 – 413, Jan. 2004.
- [14] Bhim Singh, P. Jayaprakash and D. P. Kothari, "Adaline Based Control of Capacitor Supported DVR for Distribution Systems," Journal of Power Electronics, Vol. 9, No. 3, May 2009.

- [15] Chauhan, Y.K.; Jain, S.K. and Singh, B.; , "A Prospective on Voltage Regulation of Self-Excited Induction Generators for Industry Applications," IEEE Transactions on Industry Applications , vol.46, no.2, pp.720-730, March-April 2010.
- [16] Bhim Singh, Madhusudan Singh and A. K. Tandon, "Transient Performance of Series-Compensated Three-Phase Self-Excited Induction Generator Feeding Dynamic Loads", IEEE Transactions on Industry Applications, Vol.46, No.4, Aug. 2010, pp.1271-1280
- [17] Rajesh Gupta, Member, IEEE, Arindam Ghosh, Fellow, IEEE, and Avinash Joshi, " Performance Comparison of VSC-Based Shunt and Series Compensators Used for Load Voltage Control in Distribution Systems" IEEE Transactions on Power Delivery, vol. 26, no. 1, January 2011)
- [18] Andres E. Leon, Graduate Student Member, IEEE, Marcelo F. Farias, Pedro E. Battaiotto,"Jorge A. Solsona, Senior Member, IEEE, and María Inés Valla, Fellow, IEEEJ, "Control Strategy of a DVR to Improve Stability in Wind Farms Using Squirrel-Cage Induction Generators "IEEE Transactions on Power Systems, vol. 26, no. 3, August 2011.